



環天衛星科技股份有限公司

**PRODUCT USER MANUAL**  
**GPS RECEIVER ENGINE BOARD**  
**EM-406**

**GlobalSat Technology Corporation**

台北縣中和市建一路 186 號 16 樓(遠東世紀廣場)

16, No.186, Chien 1 Road, 235 Chung Ho City, Taipei Hsien, Taiwan ,R.O.C.

Tel: 886-2-8226-3799(Rep.)

Fax: 886-2-8226-3899

Web: [www.globalsat.com.tw](http://www.globalsat.com.tw)

E-mail: [service@globalsat.com.tw](mailto:service@globalsat.com.tw)

## **Features:**

SiRF star III high performance GPS Chip Set

Very high sensitivity (Tracking Sensitivity: -159 dBm)

Extremely fast TTFF (Time To First Fix) at low signal level

Support NMEA 0183 data protocol

Built-in SuperCap to reserve system data for rapid satellite acquisition

Built-in patch antenna

LED indicator for GPS fix or not fix

LEDOFF:	Receiver switch off
LED ON:	No fixed, Signal searching
LED Flashing:	Position Fixed

## **Specification:**

### **General**

Chipset	SiRF Star III
Frequency	L1, 1575.42 MHz
C/A code	1.023 MHz chip rate
Channels	20 channel all-in-view tracking
Sensitivity	-159 dBm

### **Accuracy**

Position	10 meters, 2D RMS 5 meters, 2D RMS, WAAS enabled
Velocity	0.1 m/s
Time	1us synchronized to GPS time

### **Datum**

Default	WGS-84
---------	--------

### **Acquisition Time**

Reacquisition	0.1 sec., average
Hot start	1 sec., average
Warm start	38 sec., average
Cold start	42 sec., average

### **Dynamic Conditions**

Altitude	18,000 meters (60,000 feet) max
Velocity	515 meters /second (1000 knots) max
Acceleration	Less than 4g
Jerk	20m/sec **3

### **Power**

Main power input	4.5V ~ 6.5V DC input
Power consumption	70mA

### **Protocol**

Electrical level	TTL level, Output voltage level: 0V ~ 2.85V
Baud rate	4,800 bps
Output message	NMEA 0183 GGA, GSA, GSV, RMC, VTG, GLL

### **Physical Characteristics**

Dimension	30mm*30mm*10.5mm
-----------	------------------

<b>Operating temperature</b>	-40°C to +85°C
------------------------------	----------------

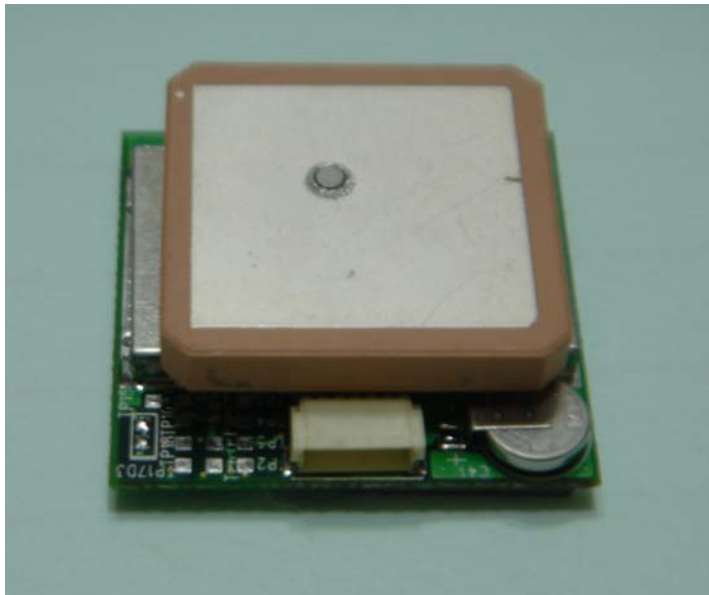

## Pin Assignment

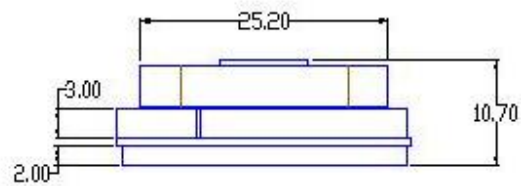
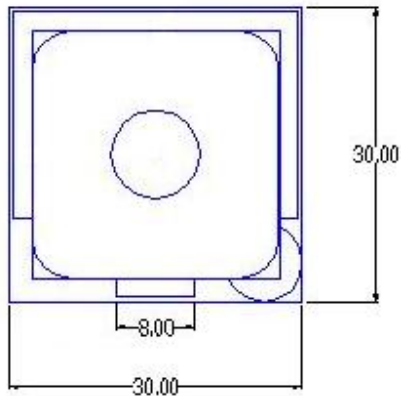
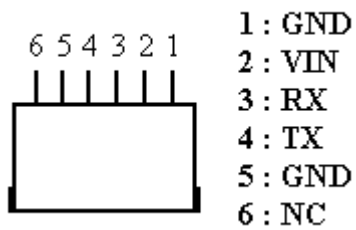

## Pin description

### \* **VIN (DC power input):**

This is the main DC supply for a 4.5V ~6.5 DC input power.

### \* **TX:**

This is the main transmits channel for outputting navigation and measurement data to user's navigation software or user written software.

### \* **RX:**

This is the main receive channel for receiving software commands to the engine board from SiRFdemo software or from user written software.

### \* **GND:**

GND provides the ground for the engine board. Connect all grounds.

# SOFTWARE COMMAND

## NMEA Output Command

### GGA-Global Positioning System Fixed Data

Table B-2 contains the values for the following example:

\$GPGGA,161229.487,3723.2475,N,12158.3416,W,1,07,1.0,9.0,M,,,0000\*18

Table B-2 GGA Data Format

Name	Example	Units	Description
Message ID	\$GPGGA		GGA protocol header
UTC Time	161229.487		hhmmss.sss
Latitude	3723.2475		ddmm.mmmm
N/S Indicator	N		N=north or S=south
Longitude	12158.3416		dddmm.mmmm
E/W Indicator	W		E=east or W=west
Position Fix Indicator	1		See Table B-3
Satellites Used	07		Range 0 to 12
HDOP	1.0		Horizontal Dilution of Precision
MSL Altitude <sup>1</sup>	9.0	meters	
Units	M	meters	
Geoid Separation <sup>1</sup>		meters	
Units	M	meters	
Age of Diff. Corr.		second	Null fields when DGPS is not used
Diff. Ref. Station ID	0000		
Checksum	*18		
<CR><LF>			End of message termination

SiRF Technology Inc. does not support geoid corrections. Values are WGS84 ellipsoid heights.

Table B-3 Position Fix Indicator

Value	Description
0	Fix not available or invalid
1	GPS SPS Mode, fix valid
2	Differential GPS, SPS Mode, fix valid
3	GPS PPS Mode, fix valid

## GLL-Geographic Position-Latitude/Longitude

Table B-4 contains the values for the following example:

\$GPGLL,3723.2475,N,12158.3416,W,161229.487,A\*2C

Table B-4 GLL Data Format

Name	Example	Units	Description
Message ID	\$GPGLL		GLL protocol header
Latitude	3723.2475		ddmm.mmmm
N/S Indicator	n		N=north or S=south
Longitude	12158.3416		dddmm.mmmm
E/W Indicator	W		E=east or W=west
UTC Position	161229.487		hhmmss.sss
Status	A		A=data valid or V=data not valid
Checksum	*2C		
<CR><LF>			End of message termination

## GSA-GNSS DOP and Active Satellites

Table B-5 contains the values for the following example:

\$GPGSA,A,3,07,02,26,27,09,04,15,,,,,1.8,1.0,1.5\*33

Table B-5 GSA Data Format

Name	Example	Units	Description
Message ID	\$GPGSA		GSA protocol header
Mode1	A		See Table B-6
Mode2	3		See Table B-7
Satellite Used <sup>1</sup>	07		Sv on Channel 1
Satellite Used <sup>1</sup>	02		Sv on Channel 2
.....			
Satellite Used <sup>1</sup>			Sv on Channel 12
PDOP	1.8		Position dilution of Precision
HDOP	1.0		Horizontal dilution of Precision
VDOP	1.5		Vertical dilution of Precision
Checksum	*33		
<CR><LF>			End of message termination

1. Satellite used in solution.

Table B-6 Mode1

Value	Description
M	Manual-forced to operate in 2D or 3D mode
A	2Dautomatic-allowed to automatically switch 2D/3D

Table B-7 Mode 2

Value	Description
1	Fix Not Available
2	2D
3	3D

## GSV-GNSS Satellites in View

Table B-8 contains the values for the following example:

\$GPGSV,2,1,07,07,79,048,42,02,51,062,43,26,36,256,42,27,27,138,42\*71

\$GPGSV,2,2,07,09,23,313,42,04,19,159,41,15,12,041,42\*41

Table B-8 GSV Data Format

Name	Example		Description
Message ID	\$GPGSV		GSV protocol header
Number of Messages <sup>1</sup>	2		Range 1 to 3
Message Number <sup>1</sup>	1		Range 1 to 3
Satellites in View	07		
Satellite ID	07		Channel 1(Range 1 to 32)
Elevation	79	degrees	Channel 1(Maximum90)
Azimuth	048	degrees	Channel 1(True, Range 0 to 359)
SNR(C/No)	42	dBHz	Range 0 to 99,null when not tracking
.....			.....
Satellite ID	27		Channel 4 (Range 1 to 32)
Elevation	27	Degrees	Channel 4(Maximum90)
Azimuth	138	Degrees	Channel 4(True, Range 0 to 359)
SNR(C/No)	42	dBHz	Range 0 to 99,null when not tracking
Checksum	*71		
<CR><LF>			End of message termination

Depending on the number of satellites tracked multiple messages of GSV data may be required.

## RMC-Recommended Minimum Specific GNSS Data

Table B-10 contains the values for the following example:

\$GPRMC,161229.487,A,3723.2475,N,12158.3416,W,0.13,309.62,120598,\*,\*10

Table B-10 RMC Data Format

Name	Example	Units	Description
Message ID	\$GPRMC		RMC protocol header
UTC Time	161229.487		hhmmss.sss
Status	A		A=data valid or V=data not valid
Latitude	3723.2475		ddmm.mmmm
N/S Indicator	N		N=north or S=south
Longitude	12158.3416		dddmm.mmmm
E/W Indicator	W		E=east or W=west
Speed Over Ground	0.13	knots	
Course Over Ground	309.62	degrees	True
Date	120598		ddmmvy
Magnetic Variation <sup>2</sup>		degrees	E=east or W=west
Checksum	*10		
<CR><LF>			End of message termination

SiRF Technology Inc. does not support magnetic declination. All “course over ground” data are geodetic WGS48 directions.

## VTG-Course Over Ground and Ground Speed

\$GPVTG,309.62,T,,M,0.13,N,0.2,K\*6E

Name	Example	Units	Description
Message ID	\$GPVTG		VTG protocol header
Course	309.62	degrees	Measured heading
Reference	T		True
Course		degrees	Measured heading
Reference	M		Magnetic
Speed	0.13	knots	Measured horizontal speed
Units	N		Knots
Speed	0.2	Km/hr	Measured horizontal speed
Units	K		Kilometers per hour
Checksum	*6E		
<CR><LF>			End of message termination